



# More Precision

**MSC7401** // Miniature sensor controller for inductive displacement sensors





- Compact and robust aluminum housing (IP67)
- High resolution and linearity
- Universal application - compatible with LVDT and half-bridge sensors
- Ideal for high-volume applications in machine building and automation
- User-friendly set up and configuration via buttons or software

The new MSC7401 controller is designed to be operated with LVDT and LDR measuring gages and displacement sensors. Due to its robust aluminum housing protected to IP67, this single-channel controller is predestined for industrial measurement tasks.

A large variety of compatible, inductive displacement sensors and gages from Micro-Epsilon combined with an optimized price/performance ratio opens up numerous fields of applications in automation technology and machine building. The controller is easily set up using buttons or software.

**Exemplary configuration**  
MSC7401 with DTA-5G8-3-CA gage:



Technical Data	Channel with DTA-5G8-3-CA
Measuring range	±5mm
Linearity	30µm
Resolution	~1.2µm
Output	Analog

**Sensor connector:**  
M12x1.5 cable gland; WS15;  
Clamping range 1mm...5mm  
Alternative (option 010):  
M9 5-pole socket,  
series 712 (Binder)

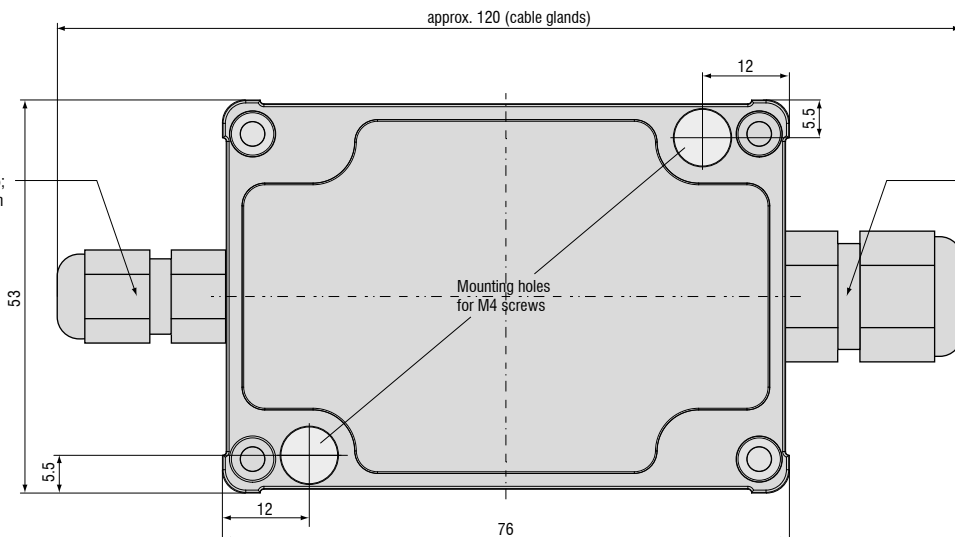

**Supply and signal connector:**  
M16x1.5 cable gland; WS19;  
Clamping range 4.5mm...10mm  
Alternative (option 010):  
M12x1 plug; 5 poles

Model		MSC7401 Miniature sensor controller
Power supply		5 V <sup>1)</sup> ... 14 V ... 30 V
Protection		reverse polarity protection, overvoltage protection
Sensor principle		full-bridge sensor/LVDT (DTA series) and half-bridge sensor (LDR series)
Input impedance (sensor)		> 100 kOhm
Gain		adjustable via buttons or software
Zero		
Output signal (adjustable)		(0)2 ... 10 VDC / 0.5 ... 4.5 V / 0 ... 5 V (R <sub>a</sub> > 1 kOhm) or (0)4 ... 20 mA (load < 500 Ohm)
Resolution <sup>2)</sup>	DTA series	13 bits (0.012 % FSO) at 50 Hz 12 bits (0.024 % FSO) at 300 Hz
	LDR series	12 bits (0.024 % FSO) at 50 Hz 11 bits (0.048 % FSO) at 300 Hz
Linearity		0.02 % FSO
Frequency response (only adjustable via software)		300 Hz (-3dB)
Storage		-40 ... +85 °C
Operation		-40 ... +85 °C
Temperature stability	DTA series	± 100 ppm FSO/K
	LDR series	± 125 ppm FSO/K
Protection class		IP67
Weight		approx. 200 g
Housing material		aluminum die casting
Connection	Cable gland	screw clamp; AWG 16 to AWG 24; with ferrule up to AWG 28
	Connector	power supply: M12x1 plug (5 poles); sensor: M9 socket; 5 poles (Binder)
EMC		DIN EN 61326-1; DIN EN 61326-2-3
Vibration		DIN EN60068-2-6
Shock	DIN EN 60068-2-27 (40 g, 6 ms, 1000 per axis)	
	DIN EN 60068-2-27 (100 g, 6 ms, 3 per axis)	

FSO = Full Scale Output

<sup>1)</sup> Restricted with load and signal span

<sup>2)</sup> Noise: AC RMS measurement via RC low-pass filter of the 1st order with f<sub>c</sub> = 5 kHz

X1: Supply and signal	X2: Sensor connection
1: output signal	1: housing/shield
2: supply voltage	2: secondary center tap
3: supply/signal ground	3: secondary +
4: housing/shield	4: secondary -
X3: Supply and signal	5: primary +
1: RS485 A	6: primary
2: RS485 B	

Control and display elements	
"Enter" button	confirmation
"↑" and "↓" buttons	parameter selection
"Menu" button	menu level
"D1" LED	display "Channel"
"D2" LED	display "E1" menu level
"D3" LED	display "E2" menu level
"D4" LED	display "Value"

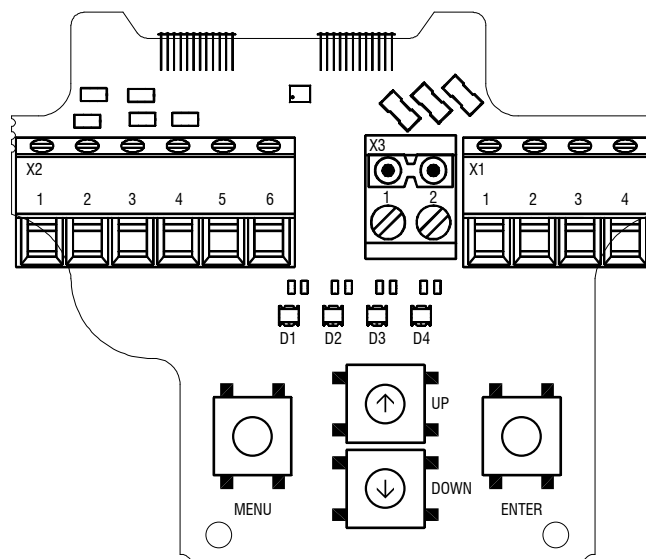

## High performance sensors made by Micro-Epsilon



Sensors and systems for displacement and position



Sensors and measurement devices for non-contact temperature measurement



2D/3D profile sensors (laser scanner)



Optical micrometers, fiber optic sensors and fiber optics



Color recognition sensors, LED analyzers and color inline spectrometer



Measurement and inspection systems